

# LW2300 Mk II

## Portable Pump

The Angus LW2300 Mk II pump is a heavy duty portable fire or industrial pump that combines the benefits of high pressure fire fighting performance with the ability to move large volumes of water continuously.

The LW2300 design has been specifically developed over many years to meet the needs of the emergency services and incorporates features to ensure easy and reliable operation in fire and rescue situations.

Electric start and exhaust ejector priming mean the pump can be put into service quickly and easily in an emergency situation by one person. Typical flows range from 1,700\* l/min at 10 bar delivery to nearly 2,000\* l/min at 6 bar.

Power is provided by a Ford in-line 4 cylinder water-cooled petrol engine developing 43 kW (59hp).

Angus fire pumps use robust, pressure-tested pump casings which allow substantial input pressures (10 bar on the LW2300) from hydrants or relay pumping. This can be boosted to high output pressures (the LW2300 pump body is tested to 20 bar, maximum working pressure 13.3 bar) without damaging the pump, a feature generally not available with lower specification pumps.

Angus Fire has over 25 years experience of manufacturing portable pumps for use world wide in fire and industrial applications.

### Applications

#### Municipal Fire Brigades

2,300 l/min at 7 bar provides a fire service with up to nine 250 l/min\* hand lines with pressure to spare.

#### Rural Fire Fighters

The 43 kW (59 hp) engine will pump over large distances and still provide usable pressure at the branchpipe.

#### Flood Relief

In situations where flow rather than pressure is critical the LW2300 will provide at least 2,300 l/min\* of salvage flow.

#### Standard Features

- Ford 4 cylinder petrol engine with self diagnostics (optional PC diagnostic connection)
- 12V electric start
- 30 litre fuel tank capacity (approx 1 1/2 hour running at maximum load)
- Fast and simple (one moving part) exhaust eject priming – 7.3m (24') in under 24 seconds
- Grade 304 stainless steel frame and fabricated components
- Light alloy, marine grade, corrosion-resistant pump body and impeller (Gunmetal optional)
- Glycerine filled compound and output pressure gauge
- Electrical power input (charging)/output point as standard

### Technical Specification

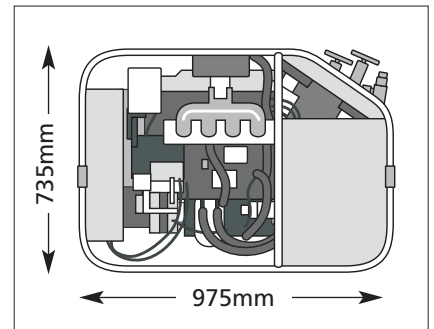

#### Dimensions

Length	975 mm (38 1/2")
Width	610 mm (24")
Height	735 mm (29")
Weight	226 kg (220 kg dry)

#### Engine

Ford TSG 416 RoCam, 4 cylinder in line, 1,600 cc, overhead camshaft, petrol engine with sequential port fuel injection.

Electronic self diagnostic facility.

Five bearing steel forged crankshaft with vibration damper.

Overhead valve, pressure lubricated via crankshaft driven pump.

Die cast light alloy cylinder head and inlet manifold.

43 kW (59 hp) at 4,000 rpm, 125.5 Nm torque (91 ft lbs) at 3,000 rpm.

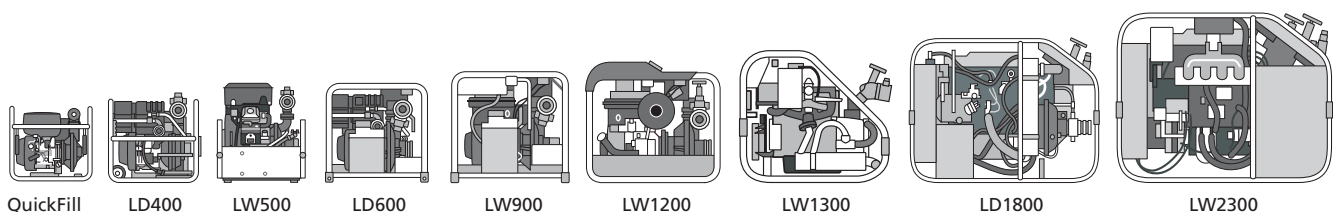

\* Based on 3m suction lift.

ref: 6340/1-07/05 page: 1 of 2

### Speed Control

Electronic governor and over speed protection with push button control

### Cooling

Indirect water cooling via heat exchanger utilising pumped water supply (up to 40°C).

Heat exchanger allows the use of anti-freeze in the engine jacket.

Heat exchanger with de-gas facility

Visual coolant (engine side) level indicator

### Electromagnetic Compatibility

Magnetic compatibility HV spark system - complies with EEC directive 89/336/EEC

### Electrical

12V negative earth system with 55 amp engine driven alternator

Power outlet socket for auxiliaries and in vehicle battery charging

### Battery

"Freedom" no maintenance battery

60 A/hr lead acid sealed unit

### Starting

12V permanently engaged starter

### Angle of Operation

45° from horizontal in any plane

### Exhaust

Stainless steel silencer arranged to direct exhaust gas away from the operator's position

DIN exhaust extension connection available on request

### Approvals

The LW2300 portable pump is CE marked for sale and use within the EEC

### Ambient Temperature Range

Full power operation

-30°C† (-22°F) to +38°C (100°F)

### Sound Level

102 dB at 7 bar outlet pressure

### Frame

Corrosion-resistant 304 grade stainless steel outer frame and fabricated components

4 x Stainless steel fold away carrying handles

### Pump

Two bearing stainless steel shaft design. Corrosion-resistant light alloy body and impeller cast from LM25 to BS1490 with TF heat treatment

Maintenance-free, spring-loaded, carbon-faced/ceramic shaft seal

Drain point

### Performance

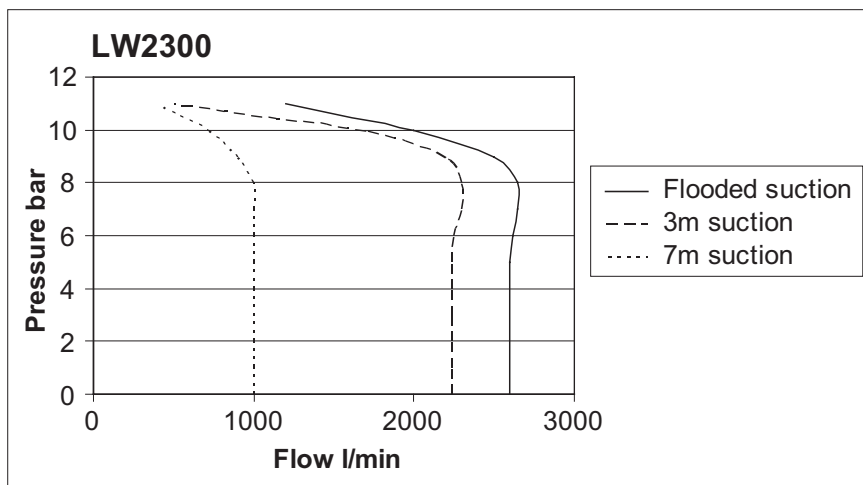

Outlet pressure*	Flow
2.5 bar	2,240 l/min
4 bar	2,240 l/min
6 bar	2,250 l/min
7 bar	2,300 l/min
8 bar	2,300 l/min
10 bar	1,700 l/min

### Pump Clearances

Centrifugal pumps will allow small solids to pass through the impeller and pump without causing damage. All Angus pumps are fitted with an inlet mesh filter which is smaller than the minimum clearance size of the impeller

Inlet filter screen size 7 mm  
Impeller clearance 11 mm

### Pump Pressure Rating

Pump housing tested to 20 bar  
LW2300 pump can accept input pressures up to 10 bar

All pump housings are pressure tested to 1½ x the nominal rated maximum output pressure (13.3 bar) to allow for high input pressures when operating in relay

### Priming

Manually actuated exhaust ejector system – single moving part design  
7.3m lift (24" Hg) in under 24 seconds

### Fuel Tank

30 litre (7 imperial gallon) – approx 1½ hours running at maximum load  
Stainless steel tank with top filling cap and inspection point.

### Inlet

Standard - 100mm (4") British Standard Round Thread male connection (other connections optional)

### Outlet

Standard - twin rotatable manual globe valves, 2½" instantaneous female couplings (Storz and other connections optional)

### Instrumentation

Inlet - glycerine filled compound gauge, 100mm Ø, scale -1 to +9 bar

Outlet - glycerine filled pressure gauge, 100mm Ø, scale 0 to 25 bar

Engine hours run meter

### Safety

Engine overheat de-rating and shut down programme

Engine detonation protection

Low oil pressure and over speed shut down

Stainless panels guard all hot areas

All controls and gauges in one easy to use location

Panel light for night-time operation

### Quality Control

Manufactured in compliance with BS EN ISO 9001:2000 quality management systems

100% quality check on all pumps for build and performance

### Options

Marine grade Gunmetal pump and impeller

Alternative inlet/outlet, Storz, US fire thread, BSP

Wheeled pump transporter

Battery state meter

Oil pressure gauge

Gauges in alternative units

Lighting mast

Diagnostic cable to couple electronic engine operating system to PC

DIN exhaust extension connection

Water temperature gauge

Trailer-mounted pump

† Special oil may be required.

\* Based on 3m suction lift.