



Portable Fire Pumps

Guide to Angus Portable Fire Pumps

Self-contained portable fire fighting pumps are an essential tool for modern fire fighters. Advances in air-cooled engines, materials and pump technology have transformed the modern pump into a reliable and practical tool for the professionally equipped fire and rescue service.

Fire pumps must not only deliver pressure and flow while being portable and easy to use, but must also meet world wide regulations governing exhaust emissions and sound levels.

The power unit

Diesel or petrol?

Petrol engines are generally lighter than diesels and are preferred for portable fire pumps. However, some applications, typically refineries and chemical plants, where an electrical spark is unacceptable, require diesel engines. Angus Fire offers 7 petrol and 3 diesel powered models.

	Power kW/(hp)	Engine type	Nominal flow (l/min) and pressure
Petrol			
QuickFill	9.6 / 13	1 cyl air-cooled	1100 @ 2 bar
LW500	13.4 / 18	2 cyl V twin air-cooled	550 @ 7 bar
LW900	16.3 / 22	2 cyl V twin air-cooled	900 @ 7 bar
LW1200	26.0 / 35	2 cyl V twin air-cooled	1200 @ 7 bar
LW1300	30.6 / 41	4 cyl in-line water-cooled	1400 @ 7 bar
LW2300	43.0 / 59	4 cyl in-line water-cooled	2300 @ 7 bar
Diesel			
LD400	8.9 / 12	1 cyl air-cooled	800 @ 4 bar
LD600	15.0 / 20	2 cyl air-cooled	600 @ 7 bar
LD1800	44.0 / 60	4 cyl in-line water-cooled	1900 @ 7 bar



Briggs & Stratton 'V' twin air-cooled engine

Air or water-cooled?

Modern materials and construction methods mean that air-cooled engines up to 26.0 kW (35hp) are reliable, even in ambient temperatures as high as 38°C (100°F). These are more lightweight and compact than water-cooled engines.

From 13.4 kW (18hp) upwards all Angus portable pumps use a 2 cylinder, V twin layout allowing air to be circulated around both cylinders. Over 35hp, 4 cylinder, in-line, water-cooled engines are traditionally used, since water cooling is essential to remove the heat from the inner cylinders.

Water-cooled engines offer reliability, power and good torque but the water cooling has to be achieved with a heat exchanger. Pumped water can cause corrosion in the engine and separating the cooling water from the pumped water allows the use of anti-freeze in the engine block. The heat exchanger, the water and the water jacket around the engine all add weight and size. In addition, the engine may overheat if the pumped water stops flowing. All Angus water-cooled pumps are fitted with an overheat cut-out to protect the engine.

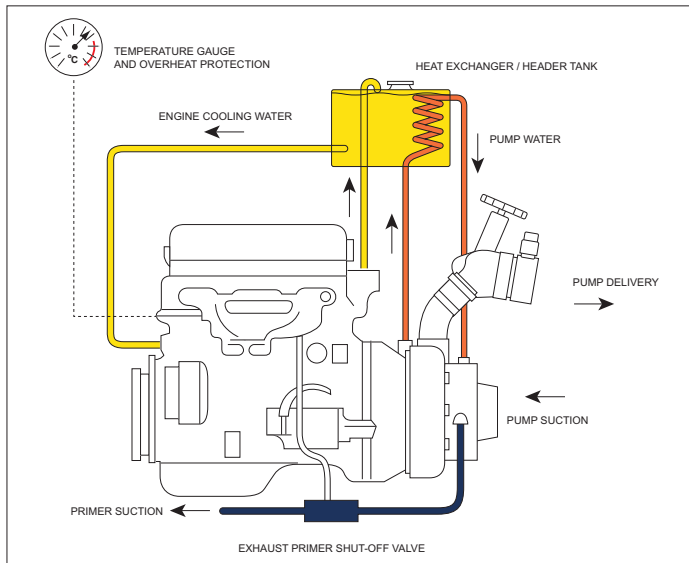

Emission regulations

In Europe engines for non-road portable machinery are governed by European Directive 97/68/EC, modified by 2002/88/EC. In the USA two standards apply, namely CARB (California Air Resources Board) and EPA (Environmental Protection Agency).

While other regulations may apply in other parts of the world, the regulations in most countries are based on one or more of the above.

All petrol Angus portable fire pumps up to 30 kW (40 hp) meet both the CARB, EPA and EEC standards for non-road portable machinery.

	Power kW/(hp)	EEC 97/68/EC & 2002/88/EC	CARB (California USA)	EPA (USA)
Petrol				
QuickFill	9.6 / 13	✓	✓	✓
LW500	13.4 / 18	✓	✓	✓
LW900	16.3 / 22	✓	✓	✓

Electrical or manual starting?

Modern electric starters and batteries ensure a first time start capability close to 100%. In the unlikely event of battery failure it is possible to provide a manual start facility on smaller pumps, but it is not generally practical to pull start any engine over 26.0 kW (35hp).

All Angus fire pumps, apart from the smallest model, incorporate electric start from an onboard battery. In addition, all pumps, up to and including the 30.6 kW (41 hp) LW1300, incorporate a manual pull hand start. However, some modern engines cannot be started manually, even when fitted with a magneto, if a charged battery is absent. This can be critical in an emergency. All Angus hand start engines can be pull started even when the battery is not present.

Electrical systems

12V electrical systems are standard on all Angus pumps and most engines are supplied with both a magneto (to provide high tension electricity for the spark) and an alternator (to provide current at 12V for battery charging and powering accessories).

Most Angus pumps are provided with a standard socket to accept a battery charging input for use while the pump is stored and to provide a source of 12V DC electricity to power accessories when the pump is running.

All Angus pump electrical systems are designed to operate even when the pump is subjected to intense water spray.

Sound levels

European regulation EN 12100-2 specifies two levels of control which relate directly to portable pumps:

Above 85 dB	Hearing protection must be available
Above 90 dB	Hearing protection must be worn and warnings must be posted indicating the area where sound levels above 90 dB can be experienced

	Sound level	Engine	Compliance with EN 12100-2
Petrol			
QuickFill	89 dB @ 3 bar	Air-cooled	✓
LW500	89 dB @ 6 bar	Air-cooled	✓
LW900	87 dB @ 6 bar	Air-cooled	✓
LW1300	98 dB @ 6 bar	Water-cooled	✓
LW2300	102 dB @ 7 bar	Water-cooled	✓
Diesel			
LD400	95 dB @ 3 bar	Air-cooled	✓
LD600	98 dB @ 3 bar	Air-cooled	✓
LD1800	108 dB @ 7 bar	Water-cooled	✓

Pump construction

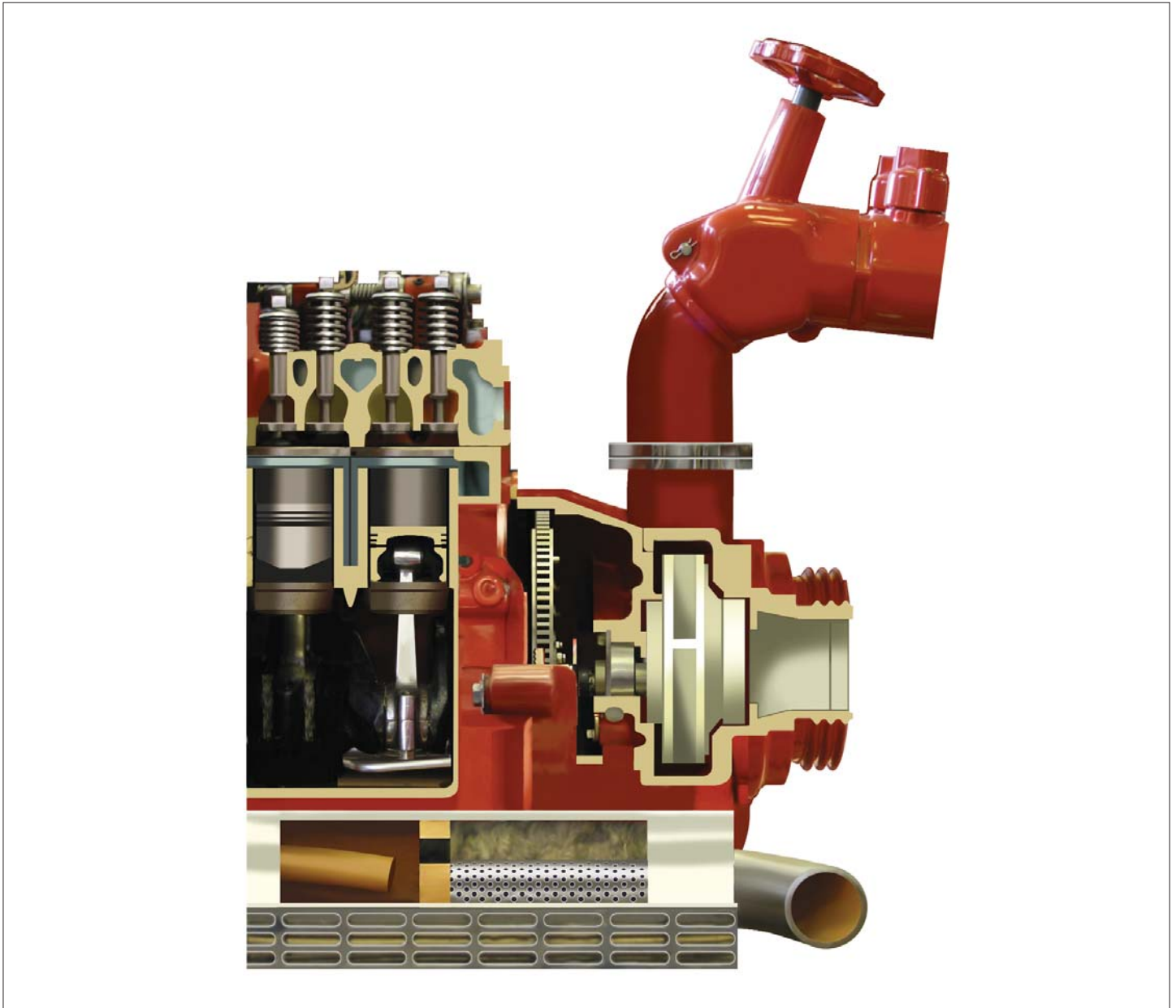

Nearly all water pumps for fire protection and emergency services are centrifugal pumps. Only centrifugal pumps offer the combination of pressure, flow and efficiency required for fire fighting and flood relief operation and have the ability to handle dirty water when necessary. Generous clearances between the impeller and the body, and the water ways inside the impeller, allow dirt and stone particles to pass through the pump without damage. In addition, all Angus pumps are fitted with an inlet filter sized to eliminate all particles that will not pass through the impeller.

Pump materials

Angus pumps are manufactured from high grade cast aluminium. Where corrosive liquids or sea water need to be pumped, casings and impellers are available in Gunmetal as an option.

Cheaper pumps, mainly used in the building trade, are made from lower grade aluminium. Angus lightweight pump bodies are machined from grade CC601 aluminium castings with the following composition:

Silicon (Si)	Iron (Fe)	Copper (Cu)	Manganese (Mn)	Magnesium (Mg)	Zinc (Zn)	Titanium (Ti)	Aluminium (Al)
6.5 – 7.5 %	0.20 %	0.05 %	0.05 %	0.25 – 0.35 %	0.05 %	0.20 %	Remainder

Gunmetal pump bodies and impellers (optional on most models) are manufactured from marine grade LG2 alloy bronze.

Priming

Centrifugal pumps are not self-priming and all the air must be removed from the pump body and suction line before the pump will work. There are two main methods used for priming.

- **Positive pump priming**

A small positive displacement pump (diaphragm, piston or vane) is linked to the pump body and the air in the suction pipe is pumped out until water reaches the pump inlet. These pumps can be hand operated or driven off the engine.

- **Exhaust venturi priming**

Gas from the engine exhaust is diverted through a small jet. A vacuum is created around the outside of the jet which can be used to suck air out of the pump. In some models the suction Venturi automatically cuts out when the water reaches the inlet, in others it is closed manually. On pumps with large engines there is enough exhaust gas to lift water from 7.3m (24 ft). However, smaller engines, with limited exhaust flow, may be limited to 4.5m (15 ft).

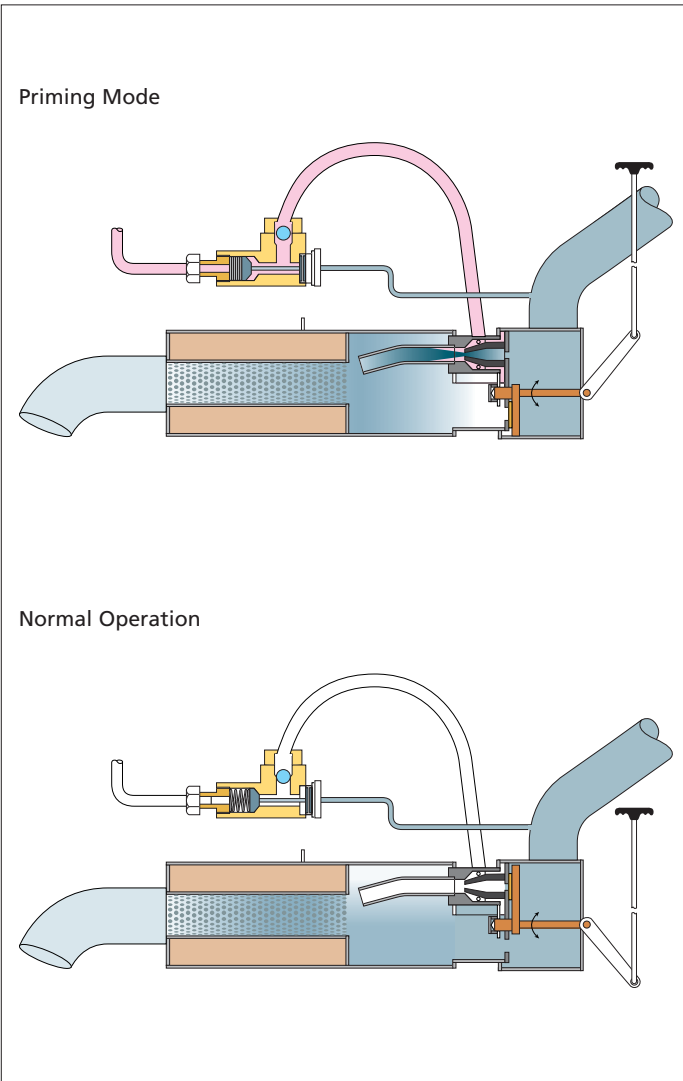

Pump standards

In the past most portable fire pumps in the UK conformed to the standard laid down by the UK fire and rescue service (JCDD 30). This called for 80 Gal/min at 80 psi and 250 Gal/min at 100 psi (7 bar), all at 3m (10 ft) suction lift. However, in recent years most fire and rescue services have moved away from this standard.

Pumps in the USA are normally manufactured to meet the National Fire Protection Association standard 1921, which calls for a range of pump sizes and duties, specified at 1.5m (5 ft) suction lift.

NFPA Designation	Nominal Flow range US Gal/min	Nominal Pressure psi
Transfer	200/300/500	15
Supply	100/250/500	50
Wildland	35/50/75	150
Combination	75/150/200 and 35/40/50	25 and 150
Attack	75/150/250	150

Other European countries have generated standards to meet local conditions. Together with the UK standard JCDD 30, these have now been replaced by European standard EN 14466 which specifies a range of pump performance categories:

EN 14466 Designation	Minimum nominal flow range l/min	Nominal Pressure bar	Angus Pumps with outputs falling into EN 14466 classes
FPN 6 - 500	500	6	LW500
FPN 10 - 1000	1000	10	LW1300 LW1200 LD1800
FPN 10 - 1500	1500	10	LW2300

Other performance ranges cover nominal pressures of 15 and 40 bar.

Selection of pump size

Portable fire pumps perform three different functions:

- Relay pumping
- Feeding one or more fire hoses from a hydrant or reservoir
- Pumping out flood water

Limitations in space and weight on fire appliances have led some fire services to replace large pumps with smaller models without compromising operational performance. The lower weight and more compact size of the Angus range of air-cooled pumps make them ideal for meeting the demands of a modern fire service.

Relay pumping

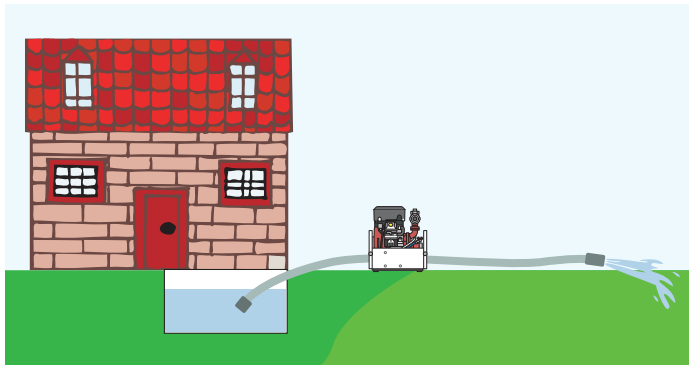
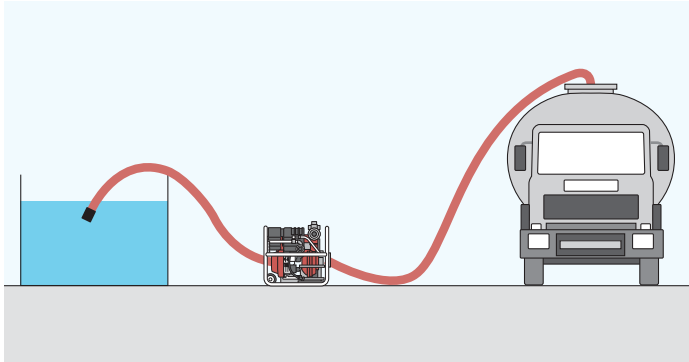
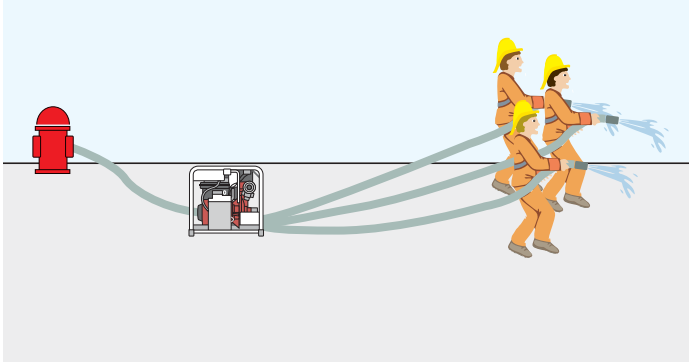
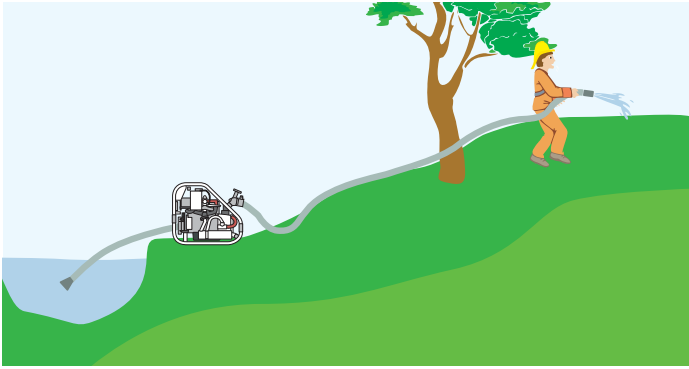

200m horizontal pipe run	Flow	Pressure at Nozzle
1 x Angus LW1300 (feeding twin hoses in parallel*)	1,450 l/min	1.8 bar
1 x Angus LW900 (feeding twin hoses in parallel*)	790 l/min	1.6 bar
1 x Angus LW500 (single hose*)	420 l/min	1.6 bar

* based on Ø 64mm Angus Duraline hose with instantaneous couplings and 3m suction

Fire hose operation from hydrant or reservoir

The number of hoses available from a single pump varies according to the inlet pressure. For an outlet pressure of 7 bar, the following number of hoses can be operated simultaneously:

Number of hoses that can be supplied at one time		
2.0 bar positive inlet pressure	@ 220 l/min per nozzle	@ 400 l/min per nozzle
LW1300	7	4
LW900	5	3
LW500	3	2
3m suction lift		
LW1300	6	3
LW900	4	2
LW500	2	1

Salvage applications

In salvage applications, such as pumping out a cellar, supply pressure is not critical.

The predicted time taken for three different sizes of pump to clear a cellar 4m x 3m x 3m deep containing 36,000 litres of water is compared below:

	Time to pump dry
LW1300	9 min
LW900	12 min
LW500	17 min

Pump casing pressure capability

Pumps only intended for building work are usually designed for the inlet to be at less than 1 bar (suction condition). These pumps will not withstand a large positive inlet pressure from a hydrant or relay pump.

Inlet pressure	Flow condition	Added pump pressure	Outlet pressure
-0.3 bar (3m suction lift)	Pump design flow	7.0 bar	6.7 bar
+4.0 bar (from hydrant or relay)	Pump design flow	7.0 bar	11.0 bar
+4.0 bar (from hydrant or relay)	Blocked outlet	11.0 bar	15.0 bar

When specifying a pump for fire duty where there may be a positive inlet pressure it is essential the pump casing is pressure rated accordingly.

All Angus pump bodies are tested to withstand 20 bar pressure (maximum working pressure 13.3 bar).

Frame

Portable fire pumps designed for professional fire fighting require a frame that is more robust than builders/trash pumps and manufactured from high quality materials that are both strong and resistant to corrosion. In addition, lifting handles are usually incorporated to make them transportable.

All Angus portable fire pumps are manufactured with frames manufactured from corrosion-resistant stainless steels such as SS304.

Instrumentation

All fire pumps must be equipped with an outlet pressure gauge to enable the pressure to be regulated for use in fire fighting. To aid suction priming a compound inlet gauge is also considered essential.

All Angus portable pumps (except de-watering pumps) are fitted as standard with compound inlet and outlet gauges and hours run meters. In addition, pumps with water-cooled engines are fitted with engine cooling temperature gauges or overheat cut-out protection.

Fuel tank

A fuel tank with a run time capacity of at least one hour is important in an operational environment. Larger Angus pumps incorporate the facility to re-fill the tank while the pump is running to avoid shutting off the supply of water while fire fighting. To achieve this the tank must be positioned so that any fuel spilled during re-filling cannot reach engine hot spots. One Angus pump incorporates a fuel tank that swings away from the pump frame on hinges or rails to allow safe filling without shutting down the pump.



Inlet and outlet connections

All Angus pumps are fitted as standard with one 100mm (4") inlet to provide a large-bore clear suction provision able to take a standard 100mm (4") suction hose. Smaller pumps, up to and including the LW500, are equipped as standard with a single rotateable 65mm (2½") outlet. All larger pumps carry twin rotateable 65mm (2½") outlets to accommodate larger flows.

Standard inlets are 100mm (4") round thread, outlets are 65mm (2½") Instantaneous. Pumps with Storz, Cam and Groove, BS threaded, Swedish, Italian, Spanish, Norwegian, Finnish, French, Russian and US couplings are also available.

Suction hoses

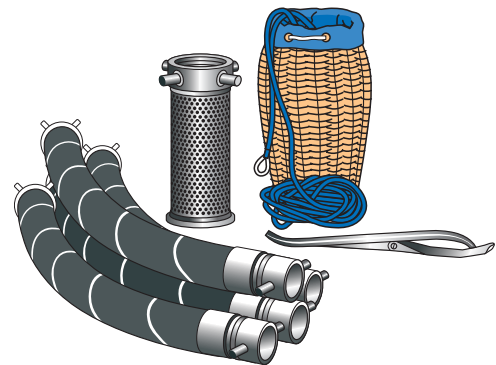

Packages of suction hoses in 3m lengths, either rubberised or plastic, with a full range of couplings, foot valves and strainers in either light alloy or Gunmetal are available from Angus Fire.

Trailer-mounted pumps

Angus Fire manufactures a wide range of trailer-mounted pumps. Pump trailers come complete with supplies of water, foam, plus suction and delivery hoses. Inductors are also available as well as custom-engineered trailers for specific applications.

Accessories

Lighting masts and wheel adapters are available on most models.

Angus Portable Fire Pumps - performance range

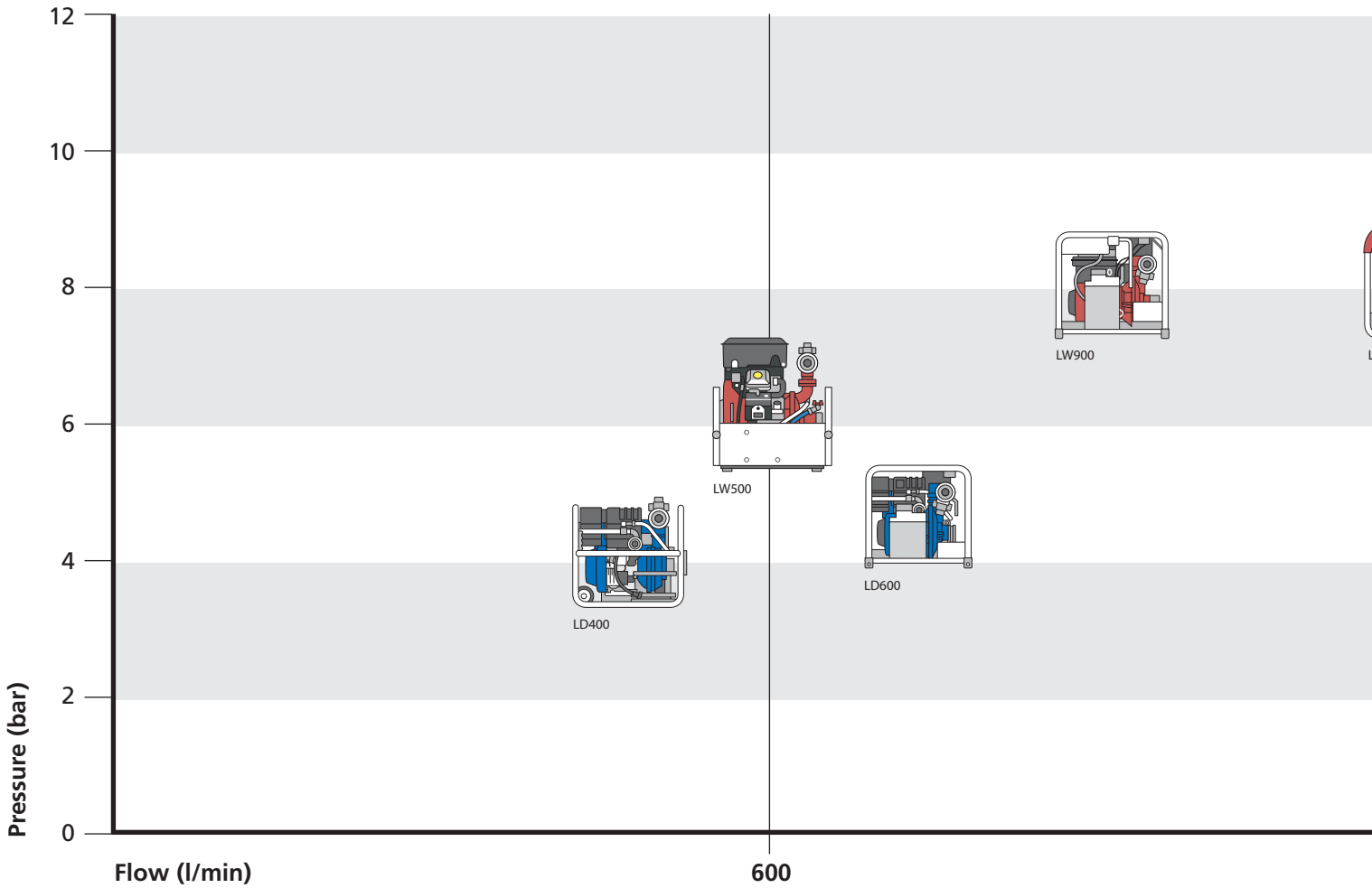

Technical Specification

Model	Power kW/(hp)	Number cylinders	Engine type	Nominal flow – l/min (EN 14466)	Nominal Pressure – bar (EN 14466)	Maximum pressure – bar at 1m suction	Salvage flow l/min (0 bat outlet) and 1m suction	EEC 97/68/EC & 2002/88/EC emission compliant	CARB (California USA) emission compliant	EPA (USA) emission compliant	Electric start	Manual start	Sound level	Compliance with EN 12100-2 sound level regulations	Fuel tank capacity - l	Run time on full tank - hour
Petrol																
QuickFill	9.6 / 13	1	Air-cooled	1100	2	6	1300	✓	✓	✓	N/A	Yes	89 dB @ 3 bar	✓	4	1
LW500	13.4 / 18	2	V twin air-cooled	550	7	9	1500	✓	✓	✓	Yes	Yes	89 dB @ 6 bar	✓	9	1 1/2
LW900	16.3 / 22	2	V twin air-cooled	900	7	10	2000	✓	✓	✓	Yes	Yes	87 dB @ 6 bar	✓	9.6	1 1/2
LW1200	26.0 / 35	2	V twin air-cooled	1200	7	10	2100	✓	✓	✓	Yes	Yes *	98 dB @ 6 bar	✓	12	1 1/2
LW1300	30.6 / 41	4	In-line water-cooled	1400	7	12	2100	X	X	X	Yes	Yes	98 dB @ 6 bar	✓	12	1 1/2
LW2300	43.0 / 59	4	In-line water-cooled	2300	7	11	2800	X	X	X	Yes	No	102 dB @ 7 bar	✓	30	1 1/4
Diesel																
LD400	8.9 / 12	1	Air-cooled	800	4	7	1400	N/A	N/A	N/A	Yes	Yes	95 dB @ 3 bar	✓	5	1 1/2
LD600	15.0 / 20	2	V twin air-cooled	600	7	8	1500	N/A	N/A	N/A	Yes	Yes *	98 dB @ 3 bar	✓	9	1 1/2
LD1800	44.0 / 60	4	In-line water-cooled	1900	7	13	2600	N/A	N/A	N/A	Yes	No	108 dB @ 7 bar	✓	31	2

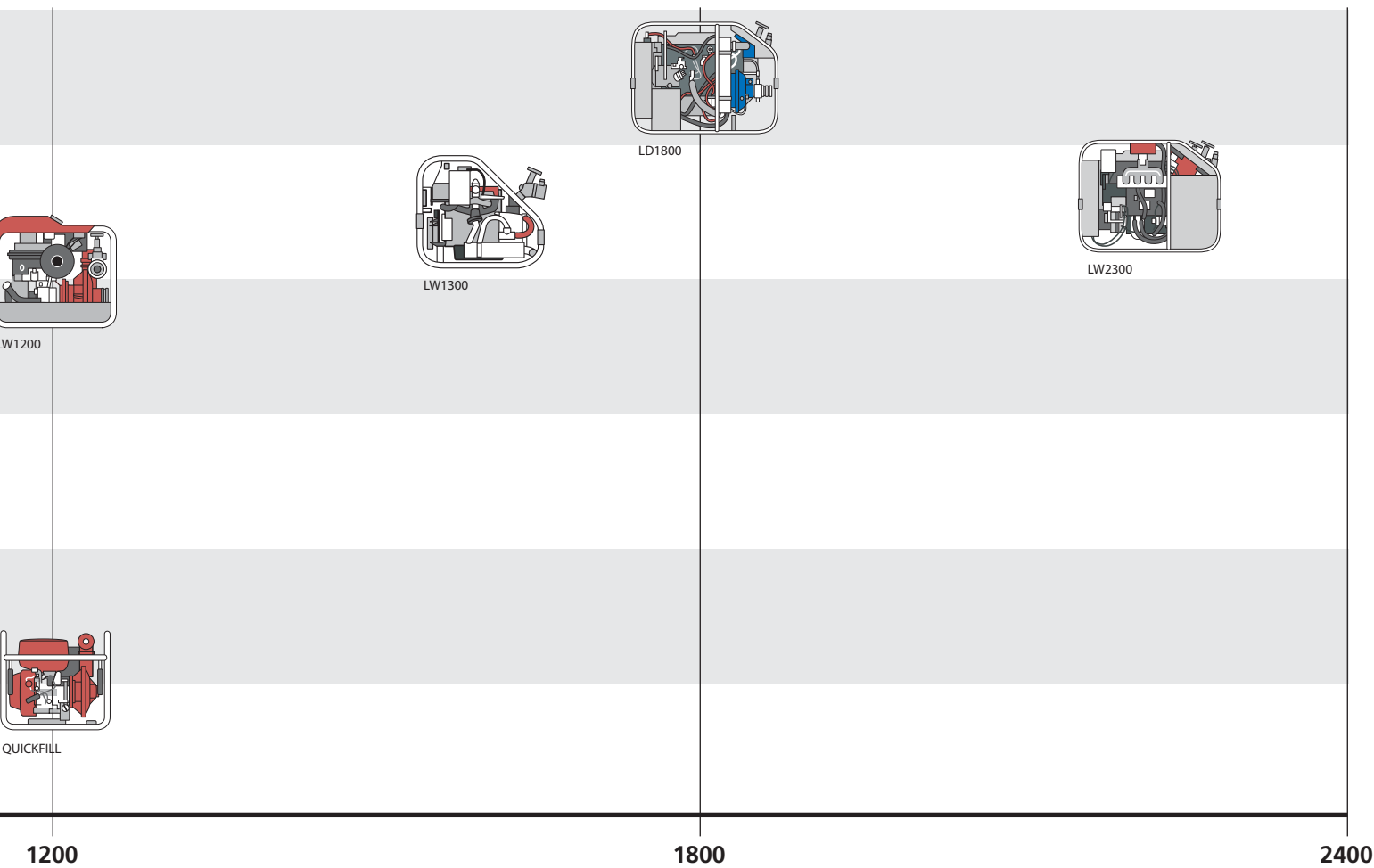

Re-fill during operation	Priming system	Time to prime to 3m - second	Maximum priming lift (m)	Maximum size of solid able to pass through pump (mm)	Overall length (mm)	Overall width (mm)	Overall height (mm)	Weight – kg (fully operational with full fuel tank) **	Inlet compound gauge – bar (glycerine filled)	Outlet pressure gauge – bar (glycerine filled)	Oil pressure warning light	Overheating warning / cut out	Fuel gauge	Temperature gauge / warning light	Hour run meter	Charging / auxiliary electrical power socket	Marine light alloy pump body and impeller	Optional gunmetal pump body and Impeller	Inlet 100mm (4") BSP Round	Number outlets – 65mm (2 1/2") instantaneous	Storz couplings available
No	Manual	26	7.0	14	550	500	575	58	x	x	x	x	x	x	x	✓	✓	x	✓	1 (R)	✓
No	Exhaust	26	4.5	10	540	500	600	74	✓	✓	x	x	x	x	✓	✓	✓	✓	✓	1 (R)	✓
✓	Exhaust	24	5.0	10	590	495	610	93	✓	✓	x	x	✓	x	✓	✓	✓	✓	✓	2	✓
✓	Exhaust	19	7.0	13	750	500	620	123	✓	✓	✓	✓	✓	✓	✓	TBA	✓	✓	✓	2	✓
✓	Exhaust	12	7.3	12	745	510	635	117	✓	✓	✓	✓	x	✓	✓	X	✓	✓	✓	2	✓
x	Exhaust	12	7.3	11	975	610	735	227	✓	✓	✓	✓	✓	✓	✓	✓	✓	✓	✓	2	✓
✓	Exhaust	25	4.5	12	590	530	610	104	✓	✓	x	x	x	x	x	N/A	✓	✓	✓	1 (R)	✓
✓	Exhaust	25	5.0	10	540	500	600	83	✓	✓	x	x	✓	x	✓	N/A	✓	✓	✓	2	✓
x	Exhaust	10	7.3	16	1030	610	740	259	✓	✓	✓	✓	x	✓	✓	✓	✓	✓	✓	2	✓

* Emergency use only ** Including oil, cooling water and battery where applicable (R) Rotatable

How does a centrifugal pump work?

Most water pumps used for fire and rescue operations, including all Angus Fire portable pumps, are “centrifugal” pumps (from the Latin, “fleeing the centre”). Centrifugal pumps offer the right balance of flow and pressure and are able to handle dirty water without becoming blocked. Positive displacement pumps, such as piston pumps can generate much greater pressures but are more complicated with many close tolerance moving parts which are expensive to make and need lubricating.

The impeller

The impeller is a metal disc with slots inside that is rotated by the pump engine. Water from the inlet enters the slots at the centre of the disc and is forced out of the ends by centrifugal force (like the water in the clothes in a spin dryer). It is then collected inside the pump casing and funnelled out through the outlet valve. The larger the diameter of the impeller, and the faster it rotates, the higher the pressure of the water at the outlet. In practice the maximum pressure that can be generated by a single impeller is around 15 atmospheres or 15 bar.¹ If more pressure is needed two impellers are used in series (a two stage pump).

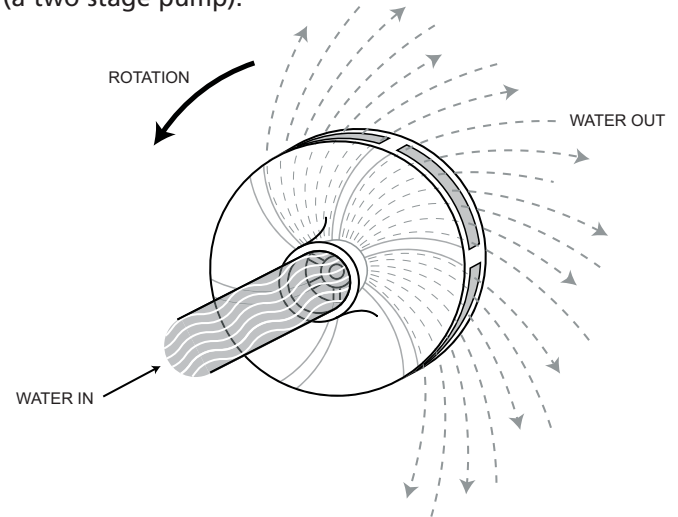

¹ One atmosphere is the pressure exerted at sea level by the atmosphere (air) pulled down by gravity. One atmosphere is also known as one bar pressure, which is roughly equal to 14.7 pounds per square inch, or 1 kg per square cm.

Suction

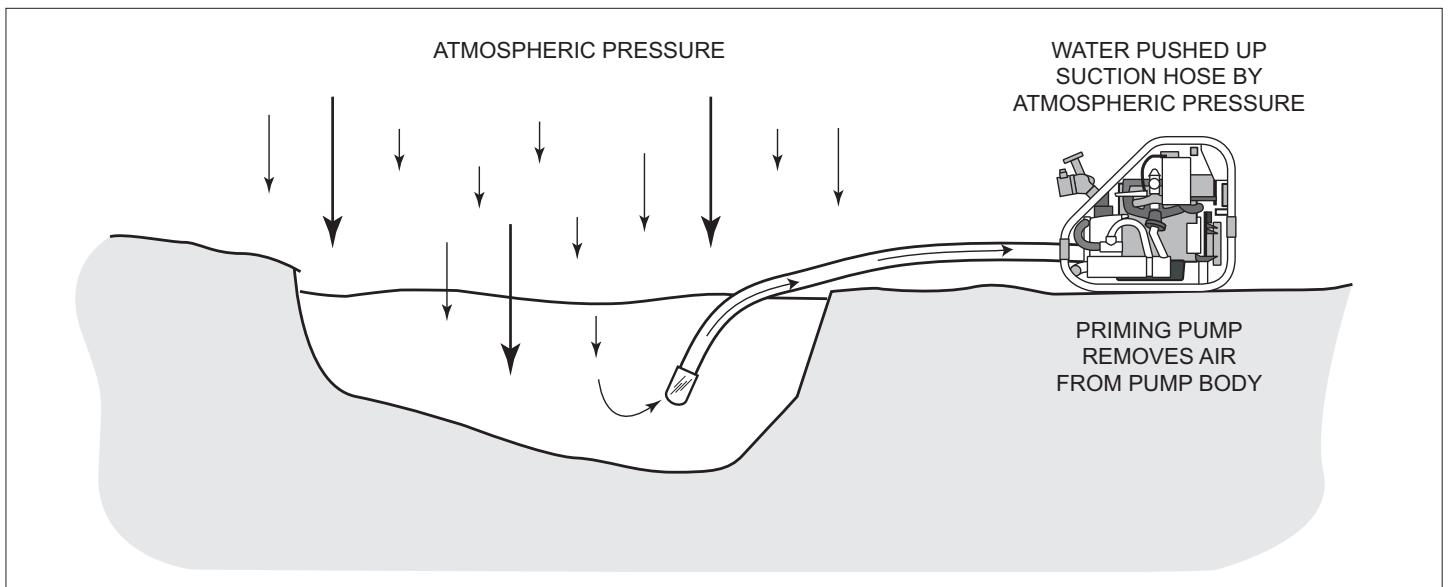

Contrary to popular belief, water is not sucked into the pump. It is pushed into the inlet by air pressure. If the air pressure in the suction pipe is reduced, the atmospheric pressure pushes on the water outside the pump, forcing it up into the pump inlet. However, the maximum atmospheric pressure available is only 1 bar or 1 kg/cm², so a centrifugal pump can never suck water from a depth greater than 10m (34 ft) because a column of water 10m high and 1 cm² in area weighs 1 kg.

In practice pumps cannot lift water further than 8m (26 ft) because the water surface being drawn into the pump turns into water vapour (cold steam) and suction is lost.

If a pump is operated above sea level the atmospheric pressure is lower, and the suction capacity of a pump will reduce by approximately 0.6m (2 ft) for every 300m (1000 ft) above sea level.

Outlet pressure is reduced by inlet pressure

Outlet pressure is generated by the impeller forcing water out of its slots and into the pump casing. The pressure it can generate depends on its speed and size and also on the inlet pressure. If the inlet pressure is positive and the pump is not relying on atmospheric pressure to force water into the inlet, for example when taking water from a hydrant, then the inlet pressure can be added to the pressure generated by the impeller. However the opposite also applies, and the outlet pressure is reduced slightly if the pump has to rely on atmospheric pressure to force water into the inlet. Angus Fire shows the flow of water for several different suction depths, or where the water is at the same height as the inlet (flooded suction) to allow the user to work out how much water can be moved. This is usually shown in the form of a graph or "pump curve".

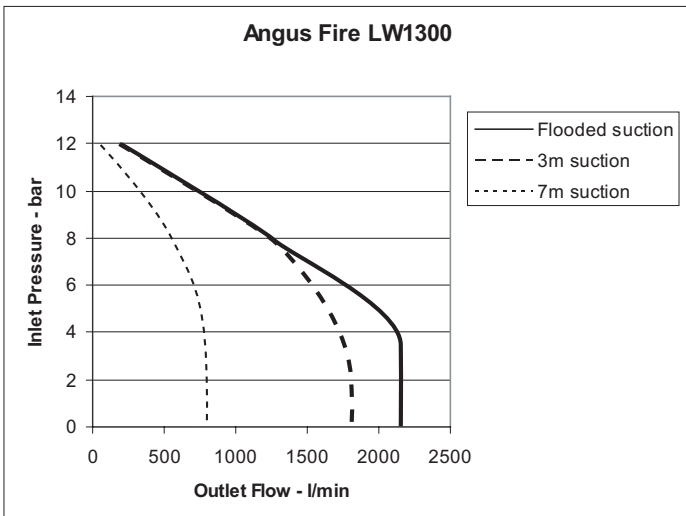

Priming

An impeller designed to pump water is not suitable for pumping air. Because of this the impeller cannot be used to remove the air in the pump casing to force water into the inlet. All centrifugal pumps need a second pumping system to remove the air from the pump body – known as "priming" (like sucking water up a straw). Priming pumps are either mechanical (often a hand pump) or use exhaust gas energy from the engine to suck air from the pump body. Once water reaches the pump inlet the impeller will take over and the priming pump is disconnected.

Pump seals

The pump body must have three openings. The suction or inlet port, the high pressure or discharge port and an inlet for the engine shaft to turn the impeller. The suction and delivery ports are connected to hoses so no air can get in. However, the engine shaft must be protected by a seal to stop air being sucked in during priming and to stop water leaking out when pumping.

The shaft seal is normally a ceramic ring pressed against a hard wearing flat carbon face by a spring. The ceramic ring rotates on the engine shaft and rubs against the carbon face which stays stationary. The ceramic face and its mating carbon face are made so flat and smooth that water and air cannot leak past them.

Pressure and flow

The pressure and flow will vary according to the distance the water has to be lifted to reach the inlet, the height the pump needs to raise the water and the pressure needed to overcome friction in the hoses.

For every 1.0 m (3.3 ft) the pump has to lift water to reach the inlet it will use only 0.1 bar of pressure. This means that in many cases suction lift is not important when calculating flow. In addition, most pump curves show the flow for a range of suction lifts which have already taken into account the suction lift pressure loss. However, when the inlet is from a high tank or a hydrant at a positive pressure, it helps the pump and the positive inlet pressure can be added into the calculation!

For every 10m (32 ft) the pump has to raise water from the outlet it will use 1.0 bar of pressure.

The loss due to friction in the delivery hose is more difficult to calculate. Long delivery hoses can cause considerable pressure losses. The loss from moving 500 l/min through 3 x 23m lengths of Angus Duraline 64mm (2½") hose is nearly 1 bar. As the flow increases the pressure loss increases even faster. For the same hose the loss at 1000 l/min would be 3.2 bar. The example below shows how to calculate the flow from an Angus LW1300 pump using the pressure/flow graph opposite.

Discharge hose 20m above pump	Pressure loss = 2.0 bar
Friction loss at 1000 l/min	Pressure loss = 3.2 bar
Total pressure loss from friction and raising water	= 5.2 bar

An Angus LW1300 pump delivering 1000 l/min will provide an outlet pressure of 9 bar after taking into account the suction loss of 0.3 bar (see graph at 3m lift). If 5.2 bar is used to lift the water and overcome the friction in the pipe the pressure left at the end of the discharge hose will be $9.0 - 5.2 = 3.8$ bar.

When calculating flows from pumps it is often necessary to work out the flow and pressure under several different conditions until a balance is found between the pump being used and the required flow and pressure.

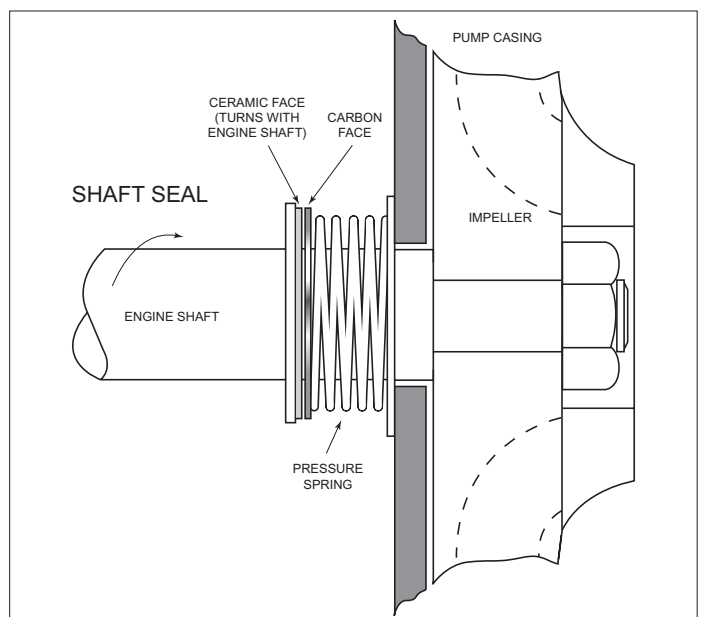

Pressure loss in fire hose

The calculation of pressure loss in hoses is complicated. To aid pump selection Angus Fire provide a free, and simple to use, software package that will calculate the losses for a wide variety of hose types, diameters and flow rates taking into account the type of coupling, the length between couplings and the expansion of the hose caused by pressure. The Angus HoseCalc programme can be downloaded free from the Angus Fire web site at www.angusfire.co.uk (Products, Fire Hose, HoseCalc link).

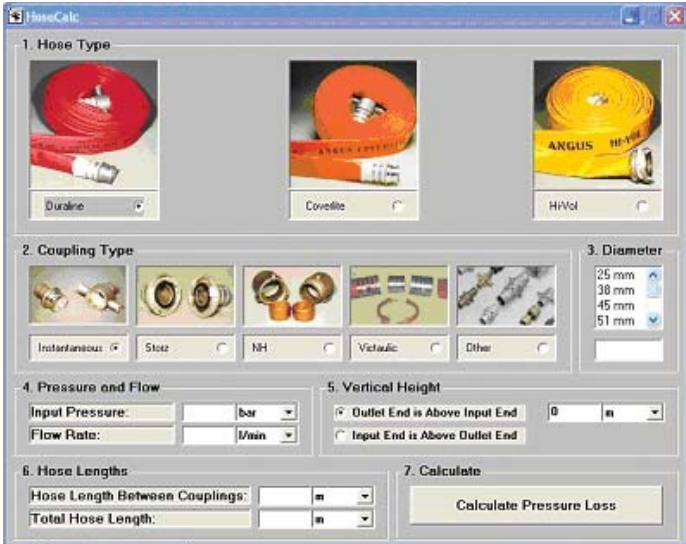

Pressure is also needed to overcome the friction in every bend, coupling and dividing breeching in the discharge hose. If too many bends, couplings and other obstacles are included the pressure losses may be too great for the pump to overcome and little or no water will flow.

Loss in first hose	3.0 bar
Loss in dividing breechings	0.6 bar
Losses in second hoses	2.7 bar
Loss in hose couplings	0.4 bar
Loss in branchpipe nozzle	0.4 bar
Total loss	7.1 bar
Pressure available at pump outlet	7.0 bar

Result – no flow!

The pressure needed at the exit of a typical fire hose to achieve a good jet or operate a foam branchpipe is at least 3 bar and can often be as high as 7 bar.

Engines at altitude

Petrol and diesel engines use air to burn fuel to produce power. The higher the engine the lower the atmospheric pressure. This reduces the amount of air the engine can burn and lowers its power. A typical engine will lose 11 to 12% of its power for every 1000m (3,280 ft) of altitude, which will have a corresponding effect on a pump's ability to move water.

Dos and Don'ts for trouble-free pumping

- Do make sure the suction hose is well connected and air tight when priming
- Do make sure the outlet valve is closed and the drain point under the pump body is closed when priming
- Do drain the pump body after pumping dirty water
- Do flush any pump used on sea water or corrosive liquids with fresh water
- Do drain the pump body if there is a danger of freezing
- Do watch to make sure the cooling water is flowing freely on a water-cooled pump engine by watching the temperature gauge or warning light
- Do start and run on water every few weeks to ensure they are working correctly, the pump seal is in good condition and the starter battery is charged
- Don't run the pump with the priming mechanism permanently engaged. Shut it off as soon as water reaches the pump body (usually indicated by a change in engine sound)
- Don't run the pump dry for long periods
- Don't run the pump against a closed outlet valve for long periods
- Don't fill the fuel tank with the engine running unless the tank is specifically designed for this purpose (most Angus models)

Technical datasheets containing further information on Angus Portable Fire Pumps are available on request from your local Angus Fire representative or from our website www.angusfire.co.uk

Angus Fire reserves the right to modify any specification without prior notice.

REF: 6344/1-07/05 © Angus Fire Printed in England



FM 00215



INVESTOR IN PEOPLE

**ANGUS
FIRE** 

THAME PARK ROAD, THAME, OXFORDSHIRE, OX9 3RT, ENGLAND

Tel: +44 (0)1844 265000 Fax: +44 (0)1844 265156

e-mail: general.enquiries@kiddeuk.co.uk Web site: www.angusfire.co.uk